

ment, using a large excess of silver nitrate, the ratio was 4.70; in a second, using a 100% excess of silver iodide, the ratio was 2.28.¹⁴

These products appeared entirely stable in air; furthermore, boiling water, concentrated ammonium hydroxide and hot caustic solution were without noticeable effect, but they dissolved readily in dilute nitric acid or in a solution of potassium cyanide in the presence of air.

Free silver was not detected in products prepared by employing an excess of the alkali metal phosphide, and here the

(14) It may be noted that after standing several months, free silver could no longer be detected in these substances.

Ag/P ratios were lower, being 2.16, 1.72 and 1.72, respectively, in three experiments. In contrast to those products precipitated in the presence of excess silver salt, these substances were pyrophoric and emitted white fumes when exposed to air.¹⁵

From the above it is apparent that silver salts do not react with tetrasodium diphosphide to form a compound of definite composition and that the Ag/P ratio depends upon the conditions of reaction.

(15) Unpublished observations, J. A. Clarke.

PHILADELPHIA 4, PENNA.

RECEIVED MARCH 28, 1951

[CONTRIBUTION FROM THE OAK RIDGE NATIONAL LABORATORY, ANALYTICAL DIVISION]

Phosphates of Niobium and Tantalum¹

BY RICHARD B. HAHN²

Niobium and tantalum form stable phosphate salts, which have not been reported previously. These are formed as amorphous, hydrated precipitates when a potassium niobate or a potassium tantalate solution is treated with an excess of phosphoric acid and nitric acid. The hydrated precipitates lose water and become crystalline upon ignition. Data are presented to show that NbOPO₄ and TaOPO₄ are the most likely formulas for the ignited compounds.

In studying the precipitation of niobium pentoxide from various aqueous solutions, it was observed that large amounts of the phosphate ion are carried down with the niobium pentoxide precipitate. Schoeller and Webb³ showed that small quantities of phosphoric acid are almost quantitatively coprecipitated with niobium pentoxide. No investigation was made by these workers, however, of the precipitation of niobium pentoxide in the presence of an excess of phosphoric acid.

Preliminary experiments showed that in the presence of an excess of a soluble orthophosphate about one third of the total weight of the precipitate is phosphorus pentoxide which is about equivalent to a one to one mole ratio of P₂O₅ and Nb₂O₅. This quantity of P₂O₅ in the precipitate could hardly be explained by occlusion or adsorption. The possibility of the formation of an insoluble phosphate of niobium was considered. C. W. Blumstrand reported an insoluble precipitate obtained by adding sodium phosphate to an aqueous solution of niobium oxytrichloride.^{4,5} However, no data are presented to show the exact composition of the precipitate. Friend states that niobium salts of phosphoric acid are unknown.⁶ Further search of the literature showed no report of a niobium phosphate, hence the following investigation was made.

Experimental

Precipitates were prepared by four methods:

(1) A solution of potassium hexaniobate is treated with an excess of phosphoric and nitric acids and digested in a hot water-bath until precipitation is complete (30–60 min.).

(2) Freshly precipitated niobium pentoxide is dissolved in an excess of oxalic acid. This solution is treated with an excess of phosphoric and nitric acids, and heated in a water-bath. The oxalic acid is destroyed by addition of solid po-

tassium bromate. The mixture is then digested until the precipitate settles.

(3) Freshly precipitated niobium pentoxide is dissolved in an excess of hydrofluoric acid. The resulting solution is treated with an excess of phosphoric acid. This solution is made alkaline with ammonium hydroxide. The mixture is then digested until the precipitate settles.

The above precipitates were air-dried and also oven-dried at 120°. The resulting solids still contained 20–40% of water and showed no X-ray diffraction pattern. These precipitates were ignited at 1000°. The resulting solids gave identical, sharp, characteristic, X-ray diffraction patterns which were different from that of niobium pentoxide and phosphoric acid obtained by ignition at the same temperature. The X-ray diffraction data are given in Table III. It is concluded, therefore, that a salt of niobium and phosphoric acid is formed.

(4) Niobium pentoxide is mixed with an excess of 85% phosphoric acid. The mixture is placed in a crucible and ignited at 1000°. The resulting residue gives X-ray diffraction patterns identical with the previously ignited precipitates, although a few faint lines corresponding to the oxide are still observed.

Analysis of the Compound.—Attempts were made to analyze the precipitates by the procedure given by Schoeller and Webb,¹¹ which consists of a sodium hydroxide fusion followed by extraction of the residue with half-saturated sodium chloride solution. Experiments with radioactive phosphorus tracer showed this method is satisfactory for separating a few milligrams of phosphate ion from niobium or tantalum, but is unsatisfactory for separating larger amounts of phosphate ion. Hence the following method was employed.

A known weight of niobium pentoxide in solution is taken and precipitated as discussed previously. The precipitate is transferred quantitatively to a 50-ml. centrifuge tube, centrifuged and washed with a 1:1 acetone-water mixture until the excess phosphoric acid is eliminated. (Pure

TABLE I
COMPOSITION OF NIOBIUM PHOSPHATE

	Per cent. Nb ₂ O ₅	Per cent. P ₂ O ₅
Niobium phosphate precipitate	65.2 ± 0.2	34.8 ± 0.2
Calculated for Nb ₂ O ₅ ·P ₂ O ₅	65.19	34.81

TABLE II
COMPOSITION OF TANTALUM PHOSPHATE

	Per cent. Ta ₂ O ₅	Per cent. P ₂ O ₅
Tantalum phosphate precipitate	75.5 ± 0.2	24.5 ± 0.2
Calculated for Ta ₂ O ₅ ·P ₂ O ₅	75.68	24.32

(1) Presented as a paper at the Southwide Chemical Conference, Atlanta, Ga., October, 1950.

(2) On loan from Wayne University.

(3) H. R. Schoeller and W. H. Webb, *Analyst*, **61**, 585 (1936).

(4) C. W. Blumstrand, *Acta Univ. Lund.*, **1**, 7 (1864).

(5) J. W. Mellor, "A Comprehensive Treatise on Inorganic and Theoretical Chemistry," Vol. IX, p. 882.

(6) J. N. Friend, "A Textbook of Inorganic Chemistry," Vol. VI, Charles Griffin and Co., Ltd., London, 1929, Part III, p. 5.

TABLE III
 X-RAY DIFFRACTION DATA^a

Niobium pentoxide		Niobium phosphate		Metaphosphoric acid		Tantalum pentoxide		Tantalum phosphate	
Intensity	$\frac{d}{n}$	Intensity	$\frac{d}{n}$	Intensity	$\frac{d}{n}$	Intensity	$\frac{d}{n}$	Intensity	$\frac{d}{n}$
halo	5.241	M	4.502	halo		halo	5.241	M	5.960
f	4.329	S	3.451	M	3.767	f	4.287	m	4.257
S	3.931	S	3.196	S	3.361	S	3.863	S	4.073
f	3.484	M	3.035	M	3.071	f	4.470	M	3.824
S	3.140	M	2.347	f	2.040	S	3.124	S	3.300
f	2.855	M	2.252	M	1.906	S	2.424	f	2.838
f	2.728	M	2.017	f	1.769	f	2.025	f	2.769
f	2.590	S	1.880	f	1.442	M	1.935	M	2.712
M	2.447	M	1.808			M	1.805	f	2.627
f	2.120	M	1.726			f	1.752	f	2.576
f	1.962	f	1.661			M	1.640	S	2.473
f	1.908	M	1.623			f	1.560	f	2.383
M	1.825	M	1.592			f	1.448	f	2.240
M	1.792	M	1.503			M	1.319	M	2.159
M	1.661	s	1.437			f	1.288	f	2.025
M	1.571	f	1.340			f	1.214	f	1.983
f	1.543	M	1.254			f	1.191	f	1.939
M	1.459	M	1.216					M	1.897
M	1.336	M	1.170					M	1.850
M	1.322	f	1.129					M	1.799
M	1.226	M	1.065					M	1.789
f	1.209	f	1.009					f	1.763
f	1.197	M	0.987					f	1.702
M	1.144	M	0.966					M	1.673
f	1.022	f	0.926					f	1.621
f	0.999	f	0.883					f	1.565
		f	0.858					f	1.537
		f	0.827					M	1.514
		f	0.815					f	1.490
								f	1.413
								f	1.363
								f	1.329
								f	1.317
								f	1.284
								f	1.273
								f	1.253

^a Debye-Scherrer method using $\text{Cu } \alpha = 1.5404 \text{ \AA}$.

water, dilute nitric acid or ammonium nitrate wash solutions cause hydrolysis of the precipitate resulting in the loss of phosphoric acid.) The washed precipitate is quantitatively transferred to a filter, dried then ignited at 1000° and weighed. The P_2O_5 content is determined by difference.

The analyses of precipitates formed by method (1) and (2) agree quite closely. The averages of several analyses are given in Table II. Precipitates formed in alkaline solution (method (3)) show a lower P_2O_5 content due to a greater degree of hydrolysis.

These data show that one mole of niobium pentoxide is combined with one mole of phosphorus pentoxide. The compound may be formulated as

- (1) NbOPO_4 , niobium oxy-orthophosphate or
- (2) NbO_2PO_3 , niobium dioxy-metaphosphate

In order to determine the proper formula the precipitate was fused with sodium hydroxide. The resulting solid was leached with water and the solution tested for ortho- and metaphosphate ions. A positive test was obtained for the orthophosphate ion only. Hence it is concluded that NbOPO_4 is the most likely formula for the compound.

Part II. Tantalum Phosphate

Since niobium was found to form a salt with phosphoric acid not previously reported, the possibility of a corresponding tantalum compound was considered. A search of the literature showed no mention of a tantalum phosphate.

Experimental

Potassium tantalate was prepared by fusing pure tantalum pentoxide with potassium hydroxide. The resulting solid was dissolved in water, allowed to stand several days then filtered. The solution was standardized by precipitating tantalum pentoxide with nitric acid after which the solution was made alkaline with ammonia, the tantalum pentoxide filtered off, washed, ignited and weighed. This precipitate was tested spectrographically and was found to be pure except for a faint trace of niobium.

Formation and Composition of Tantalum Phosphate.—A known amount of a standard solution of potassium tantalate is treated with an excess of phosphoric acid and nitric acid. The mixture is digested 30–60 minutes in a water-bath. A flocculent, gelatinous precipitate is formed. This precipitate is transferred quantitatively to a 50-ml. centrifuge tube, centrifuged and washed with a cold 1:1 acetone-water mixture until the excess phosphoric acid is eliminated. The washed precipitate is transferred quantitatively to a filter, ignited at 1000° and weighed. The P_2O_5 content is found by the difference in weights of the final precipitate and the tantalum pentoxide taken.

The averages of several analyses are given in Table II. Characteristic X-ray diffraction patterns of the ignited precipitate are given in Table III. For reasons stated under niobium phosphate, the most likely formula is considered as TaOPO_4 .

Properties and Reactions of the Compounds.—The occlusion of phosphoric acid in precipitates of niobium pentoxide acid tantalum pentoxide is due to the formation, in

part, of insoluble orthophosphates. In the presence of large excess of phosphate ions the precipitate is converted entirely to the insoluble orthophosphate. This is a flocculent gelatinous precipitate in contrast to the finely divided oxide precipitate.

The precipitated niobium (or tantalum) orthophosphate is hydrated and amorphous. Upon ignition it loses water and becomes crystalline.

The hydrated orthophosphate hydrolyzes readily in solution, reverting partially to the oxide. It is stable only in the presence of a large excess of phosphoric acid. Hydrolysis is never complete, however, and repeated washings do not remove the phosphoric acid completely. The ignited compound does not hydrolyze as readily as the hydrated form.

Analytical Applications.—Attempts were made to remove phosphate ions from solutions by adding a large excess of potassium niobate (or tantalate). Complete removal was never achieved. Hence this method cannot be employed as a method of eliminating phosphate ions from solutions. Studies are being made to find if niobium and tantalum might be separated and determined as phosphates.

Acknowledgments.—The author wishes to thank Mr. R. M. Steele for his aid in the X-ray diffraction studies and Mr. C. Feldman for the spectrographic analyses.

OAK RIDGE, TENN.

RECEIVED MARCH 5, 1951

[CONTRIBUTION FROM THE DEPARTMENT OF CHEMISTRY AND CHEMICAL ENGINEERING OF THE UNIVERSITY OF CALIFORNIA]

Dielectric Properties of Sodium, Potassium and Ammonium Bicarbonates¹

BY CHESTER T. O'KONSKI

The dielectric properties of these bicarbonates, determined from measurements on fine crystalline powders, indicate that the protons do not have the freedom postulated for certain other hydrogen-bonded solids. The effects of humidity are accounted for in the measurements and are attributed to formation of electrically conducting surface films by the adsorption of water.

Introduction

This work is related to a study of the dielectric properties of hydrogen-bonded solids. The high dielectric constant and the dielectric relaxation effects in ice and the behavior of certain of the piezoelectric and ferroelectric crystals have been attributed to proton transfer over, or tunneling through, a potential energy barrier along the O—H...O bonds.^{2,2a,3} The ferroelectric state, with its spontaneously polarized domains, enormous dielectric constant and electric hysteresis, is believed to result when the dipole orientations are closely coupled within the crystal lattice. Since there are no reliable criteria for *a priori* predictions of this type of behavior, it is of interest to examine the dielectric properties of hydrogen-bonded solids in which conditions appear favorable for proton transfer.

The shortest O—H...O distances found in the literature are those for KH_2PO_4 , 2.54 Å,⁴ and NaHCO_3 , 2.55 Å.^{5,6} It therefore is of special interest to compare NaHCO_3 and other bicarbonates with KH_2PO_4 , a ferroelectric substance which has been extensively studied.

Experimental

Method.—Attempts were made to grow large single crystals of NaHCO_3 for dielectric measurements along the different crystallographic directions. Even under carefully controlled conditions (CO_2 atmosphere, slow cooling) crystal growth on visually perfect seeds was slow and overgrowths always resulted. Measurements were therefore made on fine crystalline powders, following the method of Böttcher.⁷

(1) Presented before the Division of Physical and Inorganic Chemistry, American Chemical Society, Chicago, Illinois, Sept. 5, 1950.

(2) W. M. Latimer and W. H. Rodebush, *THIS JOURNAL*, **42**, 1419 (1920); W. M. Latimer, *Chem. Rev.*, **44**, 59 (1949).

(2a) J. C. Slater, *J. Chem. Phys.*, **9**, 16 (1941).

(3) W. F. Mason, "Piezoelectric Crystals and Their Application to Ultrasonics," D. Van Nostrand Co., Inc., New York, N. Y., 1949.

(4) J. West, *Z. Krist.*, **74**, 306 (1930).

(5) W. H. Zachariasen, *J. Chem. Phys.*, **1**, 634 (1933).

(6) For a table comparing other compounds see L. Pauling, "Nature of the Chemical Bond," Cornell University Press, Ithaca, N. Y., 1940, p. 384.

(7) C. J. F. Böttcher, *Rec. trav. chim.*, **64**, 47 (1945).

Materials.—Reagent-grade crystalline powders were sieved, and only the fractions passing a U.S. Series 200 mesh sieve (hole size 74 microns) were used. Several samples were recrystallized and gave the same results, indicating that impurities were unimportant.

Cell.—The condenser consisted of two carefully machined flat brass electrodes which were cleaned before each set of measurements. One electrode was secured in a machined Mycalex⁸ block and the other removable electrode was bolted directly on the machined supporting rim, as illustrated in Fig. 1. The area of the inner region containing the powder was 112.7 cm.² and the plate separation was normally 0.10 cm. For purposes of equilibration and to evaluate the effect of possible decomposition, carbon dioxide of controlled humidity was passed through the cell by means of two tubes push-fitted into holes in the outer electrode and capped by fine wire gauze flush with the inner surface. The cell was loaded with just enough powder, estimated from a density measurement on the sample, to fill it uniformly without excessive pressure.

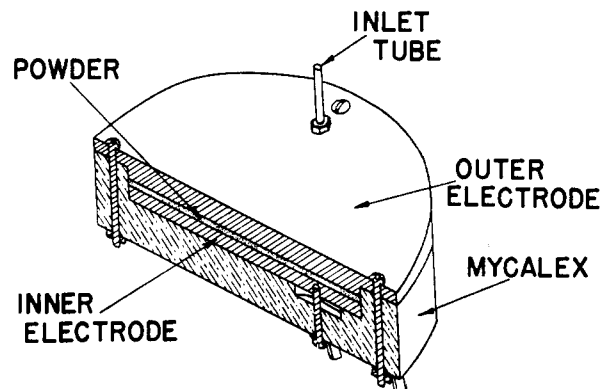

Fig. 1.—Dielectric cell for powders.

Bridge.—A shielded 1:1 ratio-arm bridge, operable over the range 20 c.p.s. to 200 kc., was used for the measurements. It consisted of the circuit shown in Fig. 2. An appropriate transformer T_1 was selected by means of a straightforward switching arrangement not shown in the diagram. With Sw_1 open, the bridge was balanced capacitively at any selected frequency by means of C_1 and C_2 , and resistively by means of the network, R_3 — R_4 , using the oscilloscope as a null indicator. The capacity-arm switch

(8) Mica with lead borate binder, having desirable mechanical and dielectric properties. Available from Electrical Specialty Company, San Francisco, California.